



SENTINEL XT™ FULL HOOD PAPR SYSTEM

MODEL NO. S-3301

Top Level Assy S-3300

USER INSTRUCTION MANUAL



Δ WARNING

IMPROPER USE OF THIS HOOD AND RESPIRATOR MAY RESULT IN PERSONAL INJURY OR DEATH. IMPROPER USE INCLUDES, BUT IS NOT LIMITED TO, USE IN ATMOSPHERES CONTAINING UNKNOWN CONTAMINATES AND/OR UNKNOWN CONCENTRATIONS OF CONTAMINANTS, USE WITHOUT ADEQUATE TRAINING, DISREGARD OF THE WARNINGS AND INSTRUCTIONS CONTAINED HEREIN AND FAILURE TO INSPECT AND MAINTAIN THIS RESPIRATOR.

THE HOOD AND RESPIRATOR ARE NOT INTENDED FOR USE IN ATMOSPHERES WHERE THE IDENTITY AND/OR CONCENTRATION OF THE CONTAMINANT IS UNKNOWN. THIS MAY RESULT IN IMMEDIATE DANGER TO PERSONNEL.

THIS HOOD AND RESPIRATOR DO NOT SUPPLY OXYGEN AND MUST NOT BE USED IN OXYGEN DEFICIENT ATMOSPHERES CONTAINING LESS THAN 19.5% OXYGEN.

Δ WARNING

TRAINING IS REQUIRED BEFORE USE OF THIS HOOD AND RESPIRATOR. FOLLOW THESE INSTRUCTIONS CAREFULLY. THIS POWERED AIR PURIFYING DEVICE IS ONLY FOR USE IN SPECIFIC ATMOSPHERES AND UNDER CERTAIN CONDITIONS. USE OF THIS RESPIRATOR WITHOUT PROPER TRAINING COULD RESULT IN SERIOUS INJURY OR DEATH.

TABLE OF CONTENTS

ITEM	PAGE
DESCRIPTION	2
GENERAL SAFETY INFORMATION	4
REPLACEMENT PARTS	8
COMFORT BELT CONFIGURATION	9
PREPARATION FOR USE.....	12
CHARGING THE LiPOLYMER BATTERY PACK	12
BATTERY USAGE AND STORAGE REQUIREMENTS	13
INSTALLING THE LiPOLYMER BATTERY PACK INTO THE BLOWER.....	14
CARTRIDGE INSTALLATION.....	16
BLOWER PLUG INSTALLATION AND AIRFLOW CHECK	17
INSTALLING THE BLOWER ONTO THE COMFORT BELT	19
BELT AND CLIP	19
TUBE COVER	19
CONNECTING THE BREATHING TUBE TO THE HOOD AND BLOWER.....	21
DONNING THE HOOD WITH A SUIT CONFIGURATION	22
REMOVING THE PAPR SYSTEM.....	26
INSPECTION	26
CLEANING.....	27
STORAGE	28
DISPOSAL OF CARTRIDGE ELEMENTS AND BATTERIES.....	28
CUSTOMER SERVICE	29
TROUBLESHOOTING.....	30

DESCRIPTION

The ILC Dover **SENTINEL XT™ FULL HOOD PAPR SYSTEM** is a blower-assisted air-purifying respirator known as **Powered Air Purifying Respirator** or PAPR. The **SENTINEL XT™ FULL HOOD PAPR SYSTEM** is comprised of the following components:

1. Sentinel XT™ Full Hood, one size fits all P/N S-3113

The Sentinel XT™ Full Hood is a loose fitting hood consisting of Spun Bond Polyolefin fabric and an optically clear plastic visor. The Spun Bond hood is equipped with a large area visor which allows for an undisturbed field of vision. The unit also includes a head harness that fits all head sizes.

2. Blower P/N S-3114

The blower is comprised of an electrical motor that drives an air blower. An on/off switch is located on top of the blower with a deconable cap protecting the switch. A red LED near the on/off switch at the top indicates when the blower is on. There is one male thread at the blower top to connect the breathing tube. There are three female threaded inlets with rubber gaskets at the blower sides. Upon starting the blower, the red LED will light, and a buzzer will sound one short beep followed by continuous LED light and no buzzer. This indicates that the blower is functioning correctly. The blower is equipped with an audio-visual low voltage alarm indicating that battery voltage is starting to drop. Alarm is given by blinking LED and successive buzzer beeps. Alarm sound is well heard within the hood. Once the low voltage alarm has started, the user must exit the contaminated area.

3. Lithium Polymer (LiPo) Battery Pack P/N S-3108

The Sentinel XT™ LiPo battery pack provides a rechargeable power source for the blower and is integrated to the blower assembly by hinged connection at the base of the blower and a latch at the top of the blower. A fuel gauge is available to display the battery life before use.

4. Cartridge P/N S-4002

ILC Dover **SENTINEL XT™ FULL HOOD PAPR SYSTEM** utilizes two **HE** cartridges. The third blower inlet must be plugged securely with the blower plug, P/N S-4006 or flat plug P/N S-4007

5. Cartridge P/N S-4012 (Optional)

The ILC Dover **SENTINEL XT™ FULL HOOD PAPR SYSTEM** alternative filter option utilizes three **Organic Vapor/Chlorine Dioxide/Chlorine/Hydrogen Chloride/Hydrogen Fluoride/Sulfur Dioxide/High Efficiency Particulate Air** cartridges.

6. Cartridge P/N S-2027 (Optional)

The ILC Dover **SENTINEL XT™ FULL HOOD PAPR SYSTEM** alternative filter option utilizes three **Chlorine/Hydrogen Chloride/Sulfur Dioxide/Chlorine Dioxide/Ammonia/Methylamine/Formaldehyde/High Efficiency Particulate Air** cartridges.

7. Comfort Belt P/N S-3104

This is a comfortable blower mounting option that allows quick and easy attachment or removal of the blower from the belt using clip-on mounting feature. The belt offers easy access to the battery for installation and removal for charging. Also facilitates the easy cleaning/disinfecting of biological materials from the belt using standard cleaning or disinfecting materials. **Note: Do not use autoclave or other high temperature sterilization methods.**

8. Decon and Quick Release Belt and Clip P/N S-4011 (Optional)

This is a blower mounting option that allows quick and easy attachment or removal of the blower from the belt. This also facilitates the easy cleaning/disinfecting of biological materials from the belt using standard cleaning or disinfecting materials. **Note: Do not use autoclave or other high temperature sterilization methods.**

9. Breathing Tubes P/N S-3109 (33”), P/N S-3110 (25”), P/N S-3508 (19”)

The breathing tubes connect the blower unit to the hood for use in supplying air from the blower to the hood. Large and small lengths are available for the comfort belt (33” and 25”).

10. Battery Charger P/N S-3107; optional multi position power cord S-2030

A charger recharges LiPolymer Battery Pack within less than 5 hours. The optional multi position power cord allows multiple charging cradles to be used simultaneously.

11. Flow Meter P/N S-2010

Used to check the ability of the blower to provide sufficient air flow to the hood. The air flow must be checked before each use.

12. Blower Plug P/N Standard S-4006 (with knob), or Alternate Blower Flat Plug P/N S-4007 with Installation and Removal Tool P/N S-4008

Required for the HE Particulate Cartridge configuration.

13. Breathing Tube and Blower Covers P/N S-3102 and S-3103

Used to protect the breathing tube and blower.

14. Sentinel XT™ Full Hood User Instruction Manual P/N S-3301

Reference document to illustrate how to operate, don, and maintain the PAPR system.

Δ WARNING

FOLLOW THESE INSTRUCTIONS CAREFULLY. THIS POWERED AIR PURIFYING DEVICE IS ONLY FOR USE IN SPECIFIC ATMOSPHERES AND UNDER CERTAIN CONDITIONS. FAILURE TO FOLLOW THESE INSTRUCTIONS CAREFULLY COULD RESULT IN SERIOUS INJURY OR DEATH.

GENERAL SAFETY INFORMATION

Intended Use

The ILC Dover **SENTINEL XT™ FULL HOOD PAPR SYSTEM** can be used as a belt mounted blower unit, connected to the hood via a flexible breathing tube. The ILC Dover **SENTINEL XT™ FULL HOOD PAPR SYSTEM** must be combined with the appropriate cartridges and battery pack. The ILC Dover **SENTINEL XT™ FULL HOOD PAPR SYSTEM** is intended to provide respiratory protection against certain particulate contaminants and/or Organic Vapors, Acid Gases, depending on the selected cartridge.

Note: Inspect emergency use respirators on a monthly basis.

Δ WARNING

THIS HOOD AND RESPIRATOR HELP PROTECT AGAINST CERTAIN AIRBORNE CONTAMINANTS. MISUSE MAY RESULT IN INJURY OR DEATH. FOR PROPER USE, SEE SUPERVISOR, USER INSTRUCTIONS, OR CALL ILC DOVER TECHNICAL SERVICE AT (800) 631-9567. USE ONLY ILC DOVER PARTS AND ACCESSORIES FOR THE ILC SENTINEL XT™ PAPR SYSTEM AS DESCRIBED IN THESE USER INSTRUCTIONS.

ALWAYS DON THE HOOD AND RESPIRATOR SYSTEM PROPERLY AND IN AN UNCONTAMINATED AREA.

DO NOT REACH YOUR HAND INTO THE HOOD IN AREAS WHERE THE AIR IS CONTAMINATED. LEAVE THE CONTAMINATED AREA AND CLEAN CONTAMINANTS FROM YOUR HANDS BEFORE REACHING INSIDE THE HOOD.

IF YOU DISCOVER ANY OF THE WEAR AND DAMAGE DESCRIBED IN THE TROUBLESHOOTING SECTION OF THIS USER INSTRUCTION, DISCARD COMPONENT AND REPLACE IT WITH A NEW ONE. FAILURE TO DO SO MAY ADVERSELY AFFECT HOOD AND RESPIRATOR PERFORMANCE AND RESULT IN SICKNESS AND DEATH.

BEFORE USE, THE WEARER MUST READ AND FULLY UNDERSTAND THESE USER INSTRUCTIONS. KEEP THIS INSERT FOR FUTURE REFERENCE. IF YOU HAVE ANY DOUBTS ABOUT THE APPLICABILITY OF THIS HOOD AND RESPIRATOR SYSTEM TO YOUR JOB SITUATION, CONSULT AN INDUSTRIAL HYGIENIST OR CALL ILC DOVER TECHNICAL SERVICE.

Use the ILC Dover **SENTINEL XT™ FULL HOOD PAPR SYSTEM** for:

Respiratory protection is provided against certain particulate contaminants and/or Organic Vapors, Acid Gases, depending on the selected cartridge.

Never use the ILC Dover **SENTINEL XT™ FULL HOOD PAPR SYSTEM** for:

Atmospheres where oxygen concentration is below 19.5%, where concentrations of contaminants are: unknown; immediately dangerous to life or health (IDLH); exceed applicable local standards or OSHA standards for maximum use concentrations for the respirator; whichever is lower. Refer to additional limitations and cautions under NIOSH Cautions and Limitations.

Respirator Selection and Training

Δ WARNING

THIS RESPIRATOR IS INTENDED TO BE USED ONLY IN CONJUNCTION WITH AN ORGANIZED RESPIRATORY PROTECTION PROGRAM WHICH COMPLIES WITH THE REQUIREMENTS OF “PRACTICES FOR RESPIRATORY PROTECTION” Z88.2-1992 AVAILABLE FROM AMERICAN NATIONAL STANDARDS INSTITUTE, 11 WEST 42ND STREET, NEW YORK, N.Y. 10036, OR WITH THE REQUIREMENTS OF OSHA STANDARD 29 CFR 1910.134 AVAILABLE FROM THE US DEPARTMENT OF LABOR, OCCUPATIONAL SAFETY AND HEALTH ADMINISTRATION, OR WITH OTHER PERTINENT NATIONAL RECOGNIZED STANDARDS.

BEFORE USE, THE EMPLOYER MUST ASSURE THAT EACH RESPIRATOR USER HAS BEEN TRAINED BY A QUALIFIED PERSON IN THE PROPER USE AND MAINTENANCE OF THE RESPIRATOR ACCORDING TO THE INSTRUCTIONS CONTAINED IN THIS USER INSTRUCTION AND OTHER APPLICABLE USER INSTRUCTIONS.

Δ WARNING

BEFORE USING THE ILC DOVER SENTINEL XT™ PAPR SYSTEM, EACH PERSON MUST READ AND UNDERSTAND THE INFORMATION IN THIS USER INSTRUCTION. USE OF THE RESPIRATOR SYSTEMS BY UNTRAINED OR UNQUALIFIED PERSONS, OR USE THAT IS NOT IN ACCORDANCE WITH THESE INSTRUCTIONS, MAY ADVERSELY AFFECT RESPIRATOR PERFORMANCE AND MAY RESULT IN INJURY OR DEATH.

Service Life of HE, OV/CD/CL/HC/HF/SD/HE, or CL/HC/SD/CD/AM/MA/FM/HE Cartridge

The useful service life of High Efficiency Particulate Filter, OV/CD/CL/HC/HF/SD/HE, or CL/HC/SD/CD/AM/MA/FM/HE cartridges will depend upon the flow rate, the specific type, volatility and concentration of the contaminants and environmental conditions such as humidity and temperature. Replace the cartridge in accordance with an established cartridge change schedule. Cartridges should be changed earlier if smell, taste or irritation from the contaminant is detected. Cartridges must be replaced if they become damaged, soiled, or if increased breathing resistance occurs.

Eye, Face and Head Protection

Δ WARNING

THESE HOODS DO NOT PROVIDE EYE, FACE OR HEAD PROTECTION WHEN EXPOSED TO EYE, FACE OR HEAD HAZARDS. THE RESPIRATOR WEARER MUST WEAR EYE, FACE AND/OR HEAD PROTECTION APPROPRIATE TO THE HAZARD. FAILURE TO DO SO MAY RESULT IN INJURY OR DEATH.

NIOSH APPROVAL

For a listing of the components in the ILC Dover respirator systems (ILC Dover SENTINEL XT™ FULL HOOD PAPR SYSTEM) that are NIOSH approved refer to the NIOSH approved label insert.

NIOSH CAUTIONS AND LIMITATIONS

- A. Not for use in atmospheres containing less than 19.5 percent oxygen.
- B. Not for use in atmospheres immediately dangerous to life or health (IDLH).
- C. Do not exceed maximum use concentrations established by regulatory standards.

- D. Do not use this respirator if airflow is less than four cfm (115 lpm) for tight-fitting facepieces or six cfm (170 lpm) for hoods and/or helmets.
- E. Follow established cartridge/canister change schedules or observe ESLI to ensure that cartridges/canisters are replaced before breakthrough occurs.
- F. Contains electrical parts which may cause an ignition in flammable or explosive atmospheres.
- G. Failure to properly use and maintain this product could result in injury or death.
- H. Follow the manufacturer's instructions for changing cartridges and/or filters.
- I. All approved respirators shall be selected, fitted, used, and maintained in accordance with MSHA, OSHA, and other applicable regulations.
- J. Never substitute, modify, add, or omit parts. Use only exact replacement parts in the configuration as specified by the manufacturer.
- K. Refer to user's instructions, and/or maintenance manuals for information on use and maintenance of these respirators.
- L. NIOSH does not evaluate respirators for use as surgical masks.

REPLACEMENT PARTS

<u>Part No.</u>	<u>Component</u>
Hood	
S-3113	Sentinel XT™ Full Hood
Blower	
S-3114	Sentinel XT™ Blower
Power Source	
S-3108	Lithium Polymer Battery Pack
Cartridges and Plug	
S-4002	HE-High Efficiency Particulate Air (2/package)
S-4012 (Optional)	OV/CD/CL/HC/HF/SD/HE Cartridge (3/package)
S-2027 (Optional)	CL/HC/SD/CD/AM/MA/FM/HE Cartridge (3/package)
S-4006	Blower Plug (with knob); used with S-4002 filters only
S-4007 (alternate)	Blower Flat Plug; used with S-4002 filters only
S-4008 (alternate)	Flat Plug Installation and Removal Tool, used with S-4007
Alternative Carrying Systems	
S-3104	Comfort Belt
S-4011 (Optional)	Decon Quick Release Belt and Clip
Accessories	
S-3107	Lithium Polymer Battery Charger
S-2010	Flow Meter
S-3106	Battery Charging Cradle
S-2030	Multi position power cord (Optional)
Alternate Hoses	
S-3109	33" Breathing Tube
S-3110	25" Breathing Tube
S-3508	19" Flexible Breathing Tube
Covers	
S-3102 (Optional)	Breathing Tube Cover
S-3103 (Optional)	Blower Cover
User Instruction Manual	
S-3301	Sentinel XT™ Full Hood User Instruction Manual

**ASSEMBLY AND PREPARATION FOR USE OF
COMFORT BELT**

**ILC DOVER SENTINEL XT™ FULL HOOD PAPR SYSTEM
HE PROTECTION COMFORT BELT CONFIGURATION**

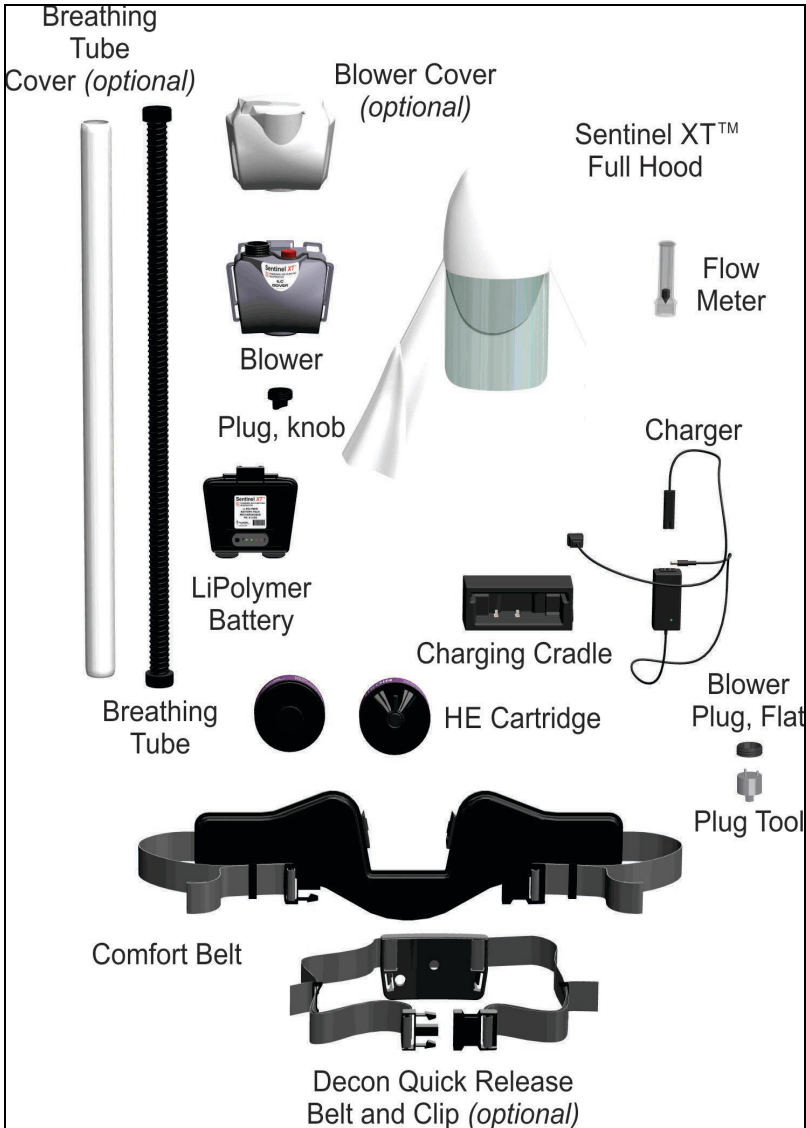

**ASSEMBLY AND PREPARATION FOR USE OF
COMFORT BELT**

**ILC DOVER SENTINEL XT™ FULL HOOD PAPR SYSTEM
OV/CD/CL/HC/HF/SD/HE PROTECTION COMFORT BELT
CONFIGURATION**

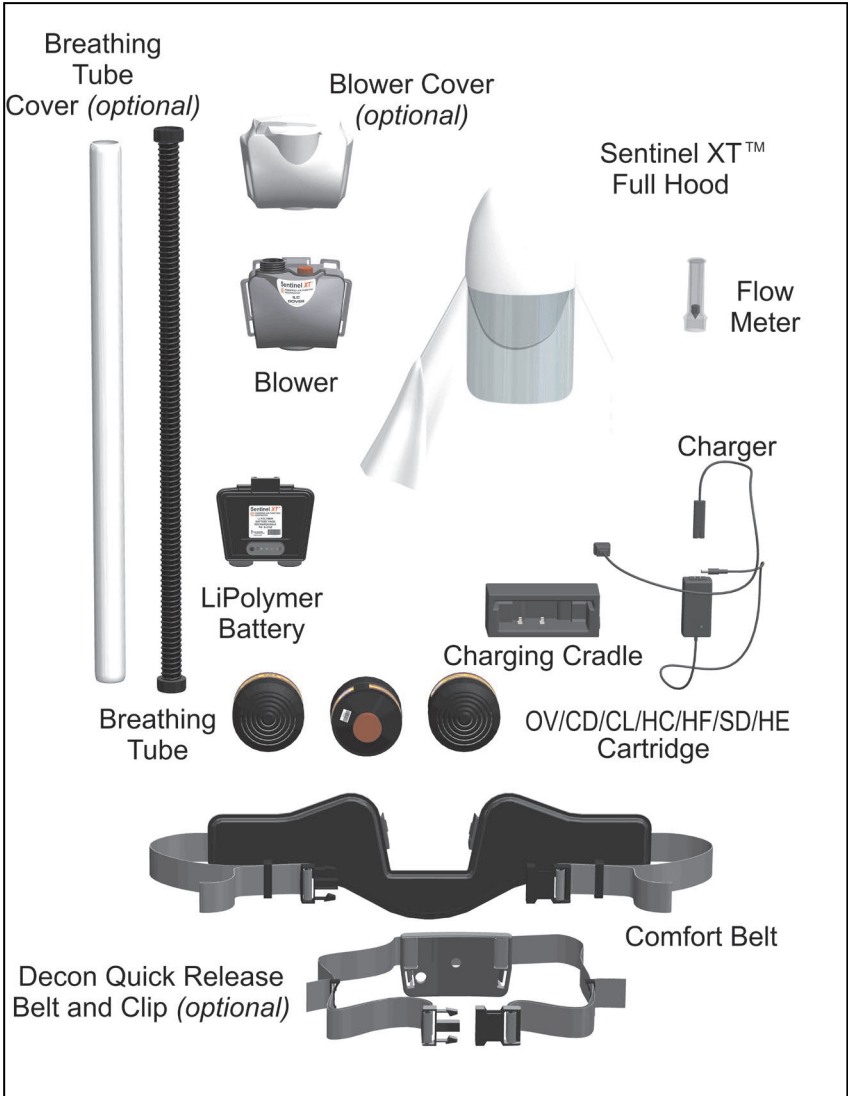

**ASSEMBLY AND PREPARATION FOR USE OF
COMFORT BELT**

**ILC DOVER SENTINEL XT™ FULL HOOD PAPER SYSTEM
CL/HC/SD/CD/AM/MA/FM/HE PROTECTION COMFORT BELT
CONFIGURATION**

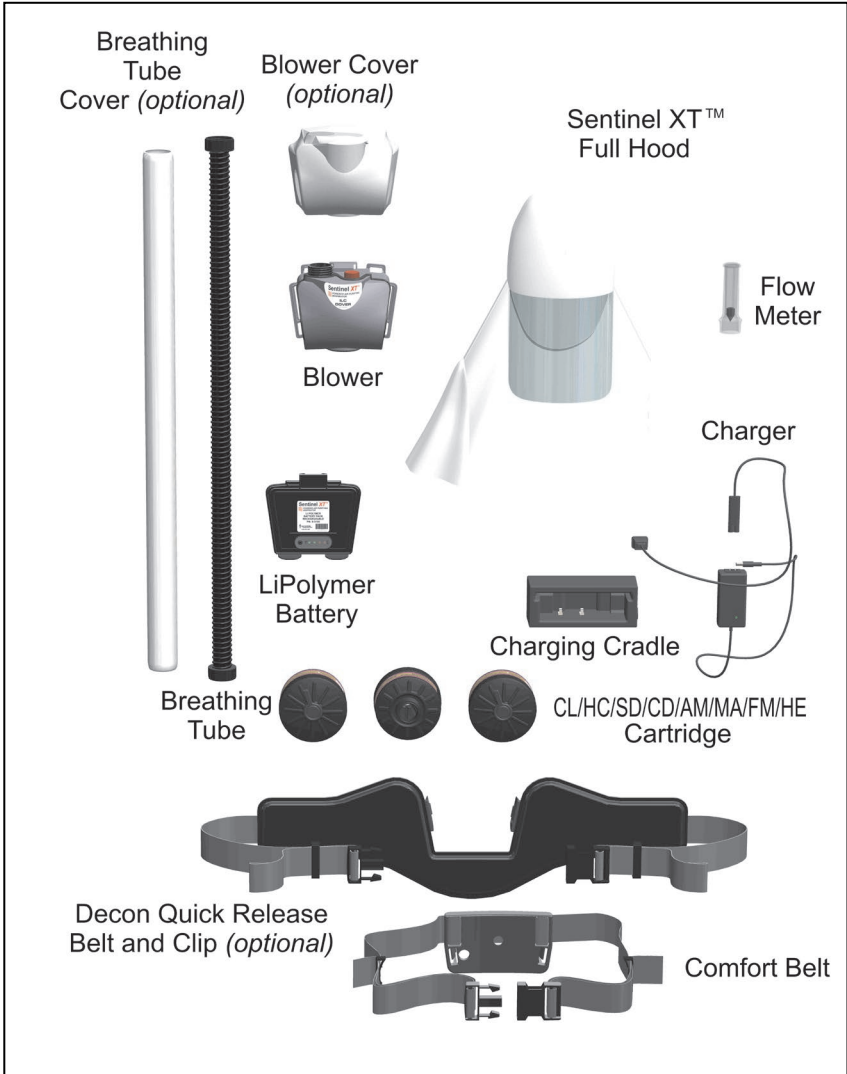

PREPARATION FOR USE USING COMFORT BELT

1. Open the package and take out the components:

- Sentinel XT™ Full Hood Users Instruction Manual S-3301
- Sentinel XT™ Full Hood S-3113
- Sentinel XT™ Blower S-3114
- Lithium Polymer Battery S-3108
- HE- High Efficiency Filter Particulate Air Cartridge S-4002, 2 each
- Optional OV/CD/CL/HC/HF/SD/HE Cartridge S-4012, 3 each
- Optional CL/HC/SD/CD/AM/MA/FM/HE Cartridge S-2027, 3 each
- Comfort Belt S-3104
- Optional Decon Quick Release Belt and Clip S-4011
- Flow meter S-2010
- Blower Plug (with knob) S-4006 or Blower Flat Plug S-4007 with Installation tool S-4008
- Lithium Polymer Battery Charger (with Instructions) S-3107
- Battery Charging Cradle S-3106
- Multi position power cord S-2030 (Optional)
- Sentinel XT™ 33" Breathing Tube S-3109
- Sentinel XT™ 25" Breathing Tube S-3110
- 19" Flexible Breathing Tube S-3508
- Breathing Tube Cover S-3102 (Optional)
- Blower Cover S-3103 (Optional)

2. Charging the LiPolymer Battery Pack:

- The battery pack should be assembled to the blower unit at all times unless the battery pack needs replacement or is charging.
- Remove the battery charging cradle from the packaging and plug the charger socket into the cradle.
- Plug the other end of the charger into an electrical outlet.
- If charger is connected to an electrical outlet before connecting to a battery, a solid green LED light indicates that the charger is operating properly.
- Next, insert the LiPolymer battery pack into the

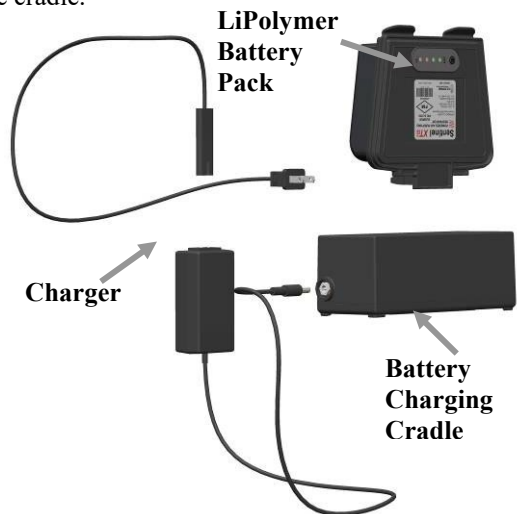

charging cradle. Be sure to insert the pack far enough down to hear/feel an engagement click.

- If the battery is not fully charged the LED light on the charger will change from green to red, indicating that charging is underway.

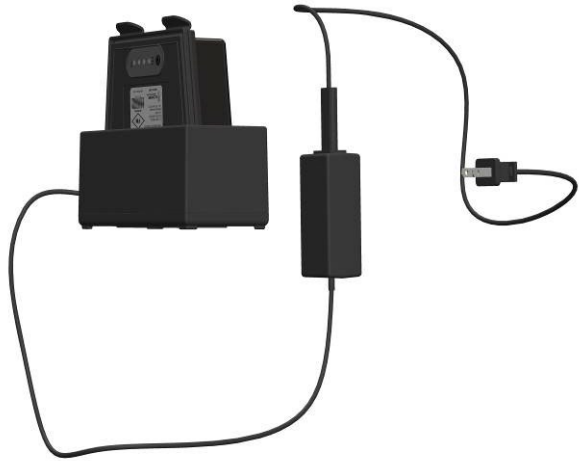

- Charge the battery for at least 5 hours (average charge time) or until the charge indicator turns green, signifying a full battery.
- After the battery is charged, remove the LiPolymer Battery Pack from the charging cradle and verify it is fully charged by viewing the battery charge gauge. The battery charge gauge is on the back of the battery pack and has four LED lights and a push button to actuate the gauge. When the push button is actuated, LED lights are displayed which indicate the level of battery charge. If four (4) lights are illuminated, the battery is fully charged. If only one, two, or three lights are illuminated, more time is needed to charge the battery. Place the battery pack back in the cradle and wait until the charger LED turns green, fully charged, before using.

3. Battery Usage and Storage Requirements:

- The Sentinel XT™ LiPolymer battery should be operated between 15°F and 110°F (-9°C to 43°C).
- The Sentinel XT™ LiPolymer battery should be stored and charged between 32°F and 95 °F (0°C to 35°C).
- Maximum storage temperature for the Sentinel XT™ LiPolymer battery is 95°F (35°C). Store in a clean, dry area, away from direct sunlight and sources of heat.
- The Sentinel XT™ LiPolymer battery should be stored at relative humidity of less than 65%.
- Do not completely discharge the battery, battery cell damage can occur. The low voltage alarm indicates that the battery needs to be charged.

- With a fully charged LiPolymer Battery the approximate run time of the Sentinel XT™ is 12 hours.
- Charge battery upon receipt unless storing for more than 1 month.
- In order to maintain proper battery performance; the battery must be reconditioned as follows every three months. This conditioning is not required, if the battery is used on a frequent basis (monthly to daily).
 - Reconditioning
 - Fully charge until green light on charger lights
 - Discharge till low voltage alarm sounds
 - Charge for 3 hours

4. Installing the LiPolymer Battery Pack in the Blower:

- A. Align the LiPolymer battery pack with the blower. Insert battery pack tabs into blower slots.



- B. Once aligned, pull the battery pack toward the blower to close. Insert battery pack latch into the blower slot.



- C. Ensure you hear/feel a click when the battery pack latch locks into blower.



Δ WARNING

DO NOT STORE THE LITHIUM POLYMER BATTERY ABOVE 90°F (32°C). STORAGE ABOVE THIS TEMPERATURE MAY RESULT IN BATTERY RUPTURE AND RESULTING EXPLOSION OR FIRE.

Δ WARNING

USE OF THESE RESPIRATOR SYSTEMS BY UNTRAINED OR UNQUALIFIED PERSONS, OR USE NOT IN ACCORDANCE WITH THESE INSTRUCTIONS MAY ADVERSELY AFFECT RESPIRATOR PERFORMANCE AND RESULT IN INJURY OR DEATH.

USE OF THESE RESPIRATOR SYSTEMS MUST BE IN ACCORDANCE WITH APPLICABLE SAFETY AND HEALTH STANDARDS, RESPIRATOR SELECTION TABLES CONTAINED IN SUCH PUBLICATIONS AS ANSI Z88.2-1992, OR PURSUANT TO THE RECOMMENDATIONS OF AN INDUSTRIAL HYGIENIST. USE OF A RESPIRATOR REQUIRES THAT A WRITTEN RESPIRATOR PROGRAM BE IN PLACE, WHICH IS IN ACCORDANCE WITH THE OSHA RESPIRATORY PROTECTION STANDARD FOUND IN 29 CFR 1910.134 PRIOR TO USING ANY RESPIRATOR SYSTEM.

BEFORE USE, THE USER MUST BE TRAINED BY THE EMPLOYER IN THE PROPER USE AND MAINTENANCE OF THE ILC DOVER SENTINEL XT™ FULL HOOD PAPR SYSTEM. SUCH TRAINING MUST BE IN ACCORDANCE WITH THIS USER INSTRUCTION. EACH PERSON USING THESE RESPIRATOR SYSTEMS MUST FIRST READ AND UNDERSTAND THIS ENTIRE USER INSTRUCTION. FAILURE TO DO SO MAY ADVERSELY AFFECT RESPIRATOR SYSTEM PERFORMANCE AND RESULT IN INJURY OR DEATH.

IF THESE RESPIRATOR SYSTEMS FAIL ANY OF THE REQUIREMENTS OF THE USER INSPECTION AND PERFORMANCE CHECK, DO NOT USE THE RESPIRATOR SYSTEM UNTIL ALL NECESSARY REPAIRS HAVE BEEN PERFORMED AND THE RESPIRATOR SYSTEMS PASS THE PERFORMANCE CHECKS. FAILURE TO DO SO MAY ADVERSELY AFFECT RESPIRATOR SYSTEM PERFORMANCE AND RESULT IN INJURY OR DEATH.

5. Cartridge Installation

The **SENTINEL XT™ FULL HOOD PAPR** system uses two (2) HE cartridges that thread into the blower inlets as shown. The third blower inlet must be plugged using the standard plug with knob (S-4006) or with the flat plug (S-4007).

Note: Screw in both HE cartridges hand tight.



Note: Screw in plug hand tight.

The alternative **SENTINEL XT™ FULL HOOD PAPR SYSTEM** uses three (3) OV/CD/CL/HC/HF/SD/HE cartridges, (S-4012), that thread into the blower inlets as shown.

Note: Screw in cartridges hand tight.



The alternative **SENTINEL XT™ FULL HOOD PAPR SYSTEM** uses three (3) CL/HC/SD/CD/AM/MA/FM/HE cartridges, (S-2027)

- Verify that the cartridges are the appropriate type for the application by examining the label attached to the cartridge.
- Remove the cartridges from their packaging and inspect for damages. If in doubt, do not use. Check that the connecting thread is not damaged.
- Check that the threads in the blower unit are in good condition and clear of foreign matter.
- Check that the blower thread inlets have the black rubber gasket seals present in the blower.
- Remove all plugs from the cartridges ends before using the system.
- Screw the cartridges into the blower threads until they are hand tight.

Δ WARNING

DO NOT OVER TIGHTEN CARTRIDGE. OVER TIGHTENING MAY RESULT IN DISTORTION OR DISPLACEMENT OF THE SEAL AND ALLOW CONTAMINATED AIR TO ENTER THE RESPIRATOR HEADPIECE. RESULTING IN INJURY OR DEATH.

6. Blower Plug Installation

S-4006 blower plug with knob

- Verify that the blower plug and blower inlet connection thread are not damaged.
- Screw the plug directly into bottom blower inlet ensuring a tight seal against inlet gasket.
- If using the blower cover, be sure **to re-check** that blower plug is installed prior to operation.



S-4007 flat blower plug with S-4008 installation tool

- Verify that the blower plug and blower inlet connection thread are not damaged.
- Using blower flat plug installation and removal tool, align and insert tool pins into blower plug. (See figure at left below)
- Using a 1/2" box end wrench, or similar tool, secure blower plug ensuring a tight seal against inlet gasket. (See figure at right below)

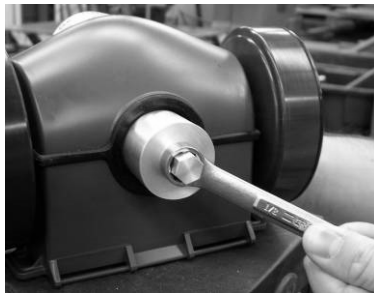

- If using the blower cover, be sure to **re-check** that blower plug is installed prior to operation.

Optional Cartridges

- Blower plug is not used with S-4012 and S-2027 Cartridges.

7. Airflow Check with the Flow Meter

- Ensure that the cartridges and plug are installed on the blower.
- Switch the blower **ON**. A short beep should sound.
- Place the flow meter in the blower's hood connector applying light pressure to allow a seal between the flow meter and the blower. Keep the flow meter vertical.
- The position of the upper (flat surface) black cone in the flow meter should be above the indication line. If any part of the upper (flat surface) of the black cone is below the line on the flow meter, **DO NOT USE** and check for:
 - Blower malfunction.
 - Clogged or damaged cartridges.
 - Low battery charge or battery malfunction.

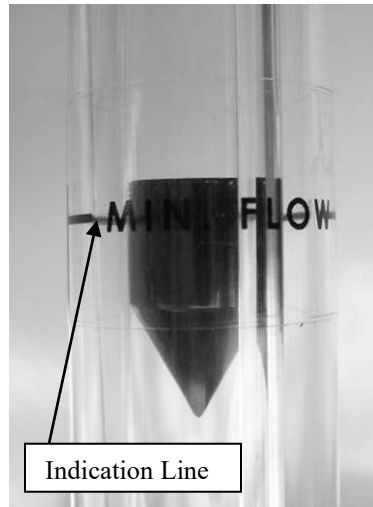

- If the upper portion of the black cone is above the indication line on the flow meter, the system is ready for use.
- DO NOT use a blower that fails the flow test.

8. Installing the Blower onto the Comfort Belt

A. Comfort Belt (S-3104)

1. Align the two mounting clips with the blower slots.

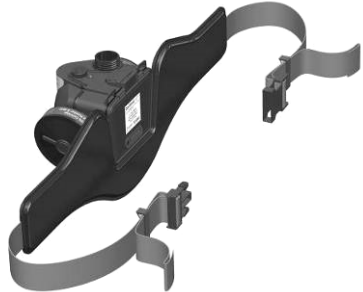
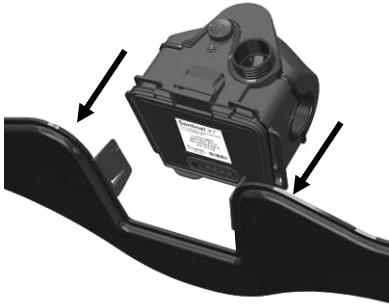

9. Positioning the blower on the Decon and Quick Release Belt and Clip. (Optional)

- For S-4011 Decon and Quick Release Belt and Clip align the quick don snap features as shown below and press belt clip firmly into place. Hole in clip should align with battery recharging port.

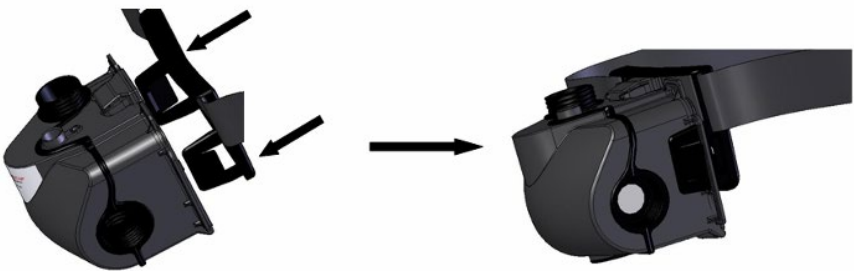

10. Installing Blower Cover and Breathing Tube Cover

- Stretch blower cover over the blower. Ensure that no blower cover material interferes with the filter inlets or breathing tube connector.

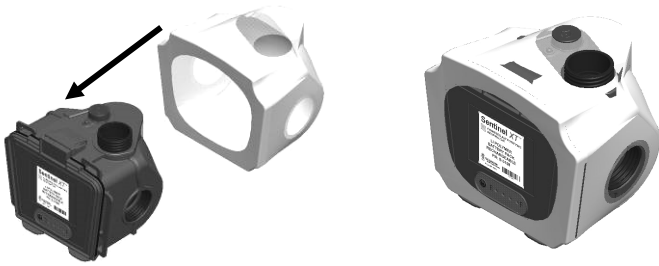

Δ WARNING

DO NOT ALLOW THE BLOWER COVER TO INTERFERE WITH THE FILTER INLETS OR BREATHING TUBE CONNECTOR. THIS MAY RESULT IN FAILURE OF ONE OR MORE OF THE CARTRIDGES OR BREATHING TUBE TO SEAL AND ALLOW CONTAMINATED AIR TO ENTER THE RESPIRATOR HEADPIECE RESULTING IN INJURY OR DEATH.

- Stretch breathing tube cover over the breathing tube. Slide the cover along the breathing tube and ensure elastic ends are placed at the breathing tube end fittings.



11. Connect the Hood to the Breathing Tube and to the Blower

- Check that both ends of the breathing tube threads have the black rubber gasket seal present. Check that the thread in the blower unit is in good condition and clear of anything that might prevent achievement of a good seal.
- Screw the end of the breathing tube into the Sentinel XT™ Full Hood and the other end into the blower unit until it is hand tight.

Do not over tighten!

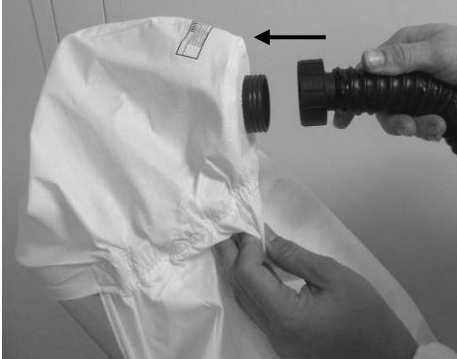

Δ WARNING

BEFORE YOU ENTER A HAZARDOUS ATMOSPHERE WEARING THIS RESPIRATOR SYSTEM, YOU MUST INSPECT THE RESPIRATOR SYSTEM, COMPLETE AN AIRFLOW CHECK, AND DON THE SYSTEM ACCORDING TO THE INSTRUCTIONS IN THIS MANUAL. FAILURE TO DO SO MAY ADVERSELY AFFECT RESPIRATOR PERFORMANCE AND MAY RESULT IN INJURY OR DEATH.

DO NOT WEAR THIS RESPIRATOR SYSTEM TO ENTER AREAS WHERE ATMOSPHERIC CONCENTRATIONS OF CONTAMINANTS ARE UNKNOWN. AREA MAY EXCEED THE MAXIMUM USE CONCENTRATION (MUC) FOR THE RESPIRATOR HOOD, OR ATMOSPHERE MAY CONTAIN LESS THAN 19.5% OXYGEN. THIS MAY RESULT IN IMMEDIATE DANGER TO PERSONNEL.

Δ WARNING

ALWAYS DON THE RESPIRATOR IN A NON-CONTAMINATED AREA. FAILURE TO PROPERLY DON THIS RESPIRATOR BEFORE ENTERING A HAZARDOUS ATMOSPHERE MAY RESULT IN INJURY OR DEATH.

IF YOU HAVE ANY DOUBTS ABOUT THE APPLICABILITY OF THE EQUIPMENT TO YOUR JOB SITUATION, CONSULT AN INDUSTRIAL HYGIENIST OR CALL THE TECHNICAL SERVICE DEPARTMENT OF ILC DOVER AT (800) 631-9567.

DO NOT REACH YOUR HAND INTO THE HOOD IN AREAS WHERE THE AIR IS CONTAMINATED. LEAVE THE CONTAMINATED AREA AND CLEAN CONTAMINANTS FROM YOUR HANDS BEFORE REACHING INSIDE THE HOOD.

12. Donning the Hood with a Suit Configuration

Don the blower and hood in a safe hazard-free area and accomplish the following:

- Check that the cartridges are properly mounted on the blower unit before donning the hood.
- Switch the blower **ON**.
- The comfort belt system allows self-donning of the hood, although the use of an assistant eases the donning process. The following donning sequence illustrates the self-donning method:

Comfort Belt Donning Sequence (S-3104)



Step 1

Turn on the blower. Allow the hood/breathing tube to drape down, then wrap the comfort belt around your waist and snap the belt buckles together. Tighten or loosen the belt in order to fit properly around the waist.



Step 2

After the belt is adjusted, pull the Sentinel XT™ Full hood over your head.



Step 3

Continue to don the hood by sliding your head through the opening and pulling down the excess skirt.



Step 4

The hood is donned and the inner skirt is ready to be tucked into the suit.



Step 5

Tuck the inner hood skirt all way around your neck and shoulders into the suit. Be sure to tuck the inner skirt **all the way** down into the suit to prevent it coming loose and pulling out during use. The picture above illustrates the completed tucking operation of the inner skirt. After the tucking portion is completed, zip up the suit all the way to the neckline. Pull down the outer skirt and allow it to drape across the shoulders.



Step 6

Front view of the completed donning sequence.



Step 7

Side view of the completed donning sequence.

- With the respirator in operation and donned according to the instructions, enter the contaminated area, breathing normally. Keep all the respirator system's components away from equipment, vehicles and other physical and chemical hazards.

Δ WARNING

DO NOT REMOVE RESPIRATOR SYSTEM WHILE YOU ARE IN A HAZARDOUS ATMOSPHERE. DOING SO MAY RESULT IN SICKNESS OR DEATH. CONTAMINANTS WHICH ARE DANGEROUS TO YOUR HEALTH INCLUDE THOSE THAT YOU MAY NOT BE ABLE TO SEE OR SMELL. LEAVE THE CONTAMINATED AREA IMMEDIATELY IF:

- **PART OF THE SYSTEM BECOMES DAMAGED.**
- **AIRFLOW INTO THE RESPIRATOR HOOD DECREASES OR STOPS.**
- **THE ALARM SIGNAL OF LOW BATTERY IS ON: RED LED FLASHES AND BUZZER BEEPS.**
- **BREATHING BECOMES DIFFICULT.**
- **YOU FEEL DIZZY OR YOUR VISION IS IMPAIRED.**
- **YOU TASTE OR SMELL CONTAMINANTS.**
- **YOUR FACE, EYES, NOSE OR MOUTH BECOME IRRITATED.**
- **YOU SUSPECT THAT THE CONCENTRATION OF CONTAMINANTS MAY HAVE REACHED LEVELS AT WHICH THIS RESPIRATOR SYSTEM MAY NO LONGER PROVIDE ADEQUATE PROTECTION.**

Δ WARNING

USE OF THESE RESPIRATOR SYSTEMS BY UNTRAINED OR UNQUALIFIED PERSONS, OR USE NOT IN ACCORDANCE WITH THESE INSTRUCTIONS MAY ADVERSELY AFFECT RESPIRATOR PERFORMANCE AND RESULT IN INJURY OR DEATH.

USE OF THESE RESPIRATOR SYSTEMS MUST BE IN ACCORDANCE WITH APPLICABLE SAFETY AND HEALTH STANDARDS, RESPIRATOR SELECTION TABLES CONTAINED IN SUCH PUBLICATIONS AS ANSI Z88.2-1992, OR PURSUANT TO THE RECOMMENDATIONS OF AN INDUSTRIAL HYGIENIST. USE OF A RESPIRATOR REQUIRES THAT A WRITTEN RESPIRATOR PROGRAM BE IN PLACE, WHICH IS IN ACCORDANCE WITH THE OSHA RESPIRATORY PROTECTION STANDARD FOUND IN 29 CFR 1910.134 PRIOR TO USING ANY RESPIRATOR SYSTEM.

BEFORE USE, THE USER MUST BE TRAINED BY THE EMPLOYER IN THE PROPER USE AND MAINTENANCE OF THE ILC DOVER SENTINEL XT™ FULL HOOD FULL HOOD SYSTEM. SUCH TRAINING MUST BE IN ACCORDANCE WITH THIS USER INSTRUCTION. EACH PERSON USING THESE RESPIRATOR

SYSTEMS MUST FIRST READ AND UNDERSTAND THIS ENTIRE USER INSTRUCTION. FAILURE TO DO SO MAY ADVERSELY AFFECT RESPIRATOR SYSTEM PERFORMANCE AND RESULT IN INJURY OR DEATH. IF THESE RESPIRATOR SYSTEMS FAIL ANY OF THE REQUIREMENTS OF THE USER INSPECTION AND PERFORMANCE CHECK, DO NOT USE THE RESPIRATOR SYSTEM UNTIL ALL NECESSARY REPAIRS HAVE BEEN PERFORMED AND THE RESPIRATOR SYSTEMS PASS THE PERFORMANCE CHECKS. FAILURE TO DO SO MAY ADVERSELY AFFECT RESPIRATOR SYSTEM PERFORMANCE AND RESULT IN INJURY OR DEATH.

REMOVING THE PAPR SYSTEM

Remove the blower and hood in a safe hazard-free area.

- Doff the hood.
- Remove the comfort belt and blower from your waist, (blower should be working at this stage).
- Turn the blower **OFF**.



INSPECTION

After each use, inspect the hood to identify signs of damage or wear that may affect performance of the respirator and reduce the degree of protection provided. The Troubleshooting Section in this manual contains a troubleshooting guide to help you identify the proper action to take for specific problems that may be detected.

Hood

Check that there are no tears or punctures in the Sentinel XT™ FULL Hood. Look closely at the stitching. There should be no tears that could permit contaminated air to enter the hood.

Visor

Look for scratches or other visual distortions that make it difficult to see through visor.

Breathing Tube

Carefully examine the entire breathing tube. Look for tears, holes or cracks. Bend the tube to verify that it is flexible.

Blower

Remove the cartridges and assure that the rubber gaskets are in place in the blower. Examine the blower housing for cracks. Replace if cracked or damaged. Examine the outside of the battery pack for cracks. Replace if damaged.

Cartridges

Examine cartridges for mechanical damage and deformities. Replace if damaged.

Blower Plug

Examine the plug in the blower inlet, and insure a tight seal against the internal gasket. Re-tighten if necessary.

Δ WARNING

IF EXCESSIVE WEAR AND/OR DAMAGE TO THE RESPIRATOR SYSTEM OR ITS COMPONENTS IS OBSERVED AT ANY TIME, DO NOT USE THE RESPIRATOR SYSTEM UNTIL ALL NECESSARY REPAIRS HAVE BEEN PERFORMED AND THE WEARER HAS SUCCESSFULLY COMPLETED THE USER PERFORMANCE CHECK DESCRIBED IN THE OPERATING INSTRUCTIONS SECTION OF THIS USER INSTRUCTION.

MISUSE MAY ADVERSELY AFFECT RESPIRATOR PERFORMANCE AND MAY RESULT IN INJURY OR DEATH.

CLEANING

Solvents should not be used to clean the Sentinel XT™ blower, LiPolymer battery pack, breathing tube and hood. Liquid solvents may chemically weaken the plastic. Wipe the blower, battery pack, breathing tube and hood with a mild cleaning solution. The decontamination solutions may be applied via cloth, paper towels, or spraying methods. Do NOT decon the battery charger. Wipe components dry with a soft cloth following decontamination and rinsing with clean water, unless noted to air dry. Never submerge or immerse any Sentinel XT™ PAPR blower, battery, filter, breathing tube, or hood components in liquid as this may permanently damage the electronics, batteries, or affect the hood or breathing tube function. Ensure all components are **completely** dry before using the system or charging the battery.

Follow the hygiene practices established by your employer for the specific contaminants to which you may have been exposed.

Δ WARNING

DO NOT CLEAN SENTINEL XT™ FULL HOOD WITH DETERGENTS THAT CONTAIN LANOLIN OR OTHER OILS SINCE THEY MAY SOFTEN OR DISTORT THE VISOR.

DO NOT WIPE THE VISOR WITH SOLVENTS LIKE MEK, ACETONE, TOLUENE, AS THOSE MAY DAMAGE OR DISTORT THE VISOR.

DO NOT SOAK THE FULL HOOD OR COMPONENTS IN CLEANING SOLUTIONS OR SOLVENTS. MISUSE MAY ADVERSELY AFFECT RESPIRATOR PERFORMANCE AND RESULT IN INJURY OR DEATH.

STORAGE

Store your respirator in a cool, dry area that is protected from exposure to hazardous contaminants and away from direct sunlight and sources of heat. The Sentinel XT™ LiPolymer battery should be stored between 32°F and 95°F. (0°C to 35°C). Maximum storage temperature for the Sentinel XT™ LiPolymer battery is 95°F (35°C). The Sentinel XT™ LiPolymer battery should be stored at relative humidity of less than 65%.

DISPOSAL OF CARTRIDGE ELEMENTS AND BATTERIES

1. Remove used cartridge elements and dispose of properly.

- Handle cartridge elements with care. Cartridge elements may contain the contaminant internally and externally that was in the atmosphere while the cartridge element was being used and must be handled as a contaminated or potentially contaminated object.
- Disposal of cartridge elements must be in accordance with state and local environmental regulations.

Δ WARNING

AFTER DECONTAMINATION, DISPOSE OF CARTRIDGE ELEMENTS IN ACCORDANCE WITH FEDERAL, STATE AND LOCAL ENVIRONMENTAL REGULATIONS. DO NOT THROW AWAY DAMAGED OR UNUSABLE CARTRIDGE ELEMENTS AS ORDINARY WASTE. IMPROPER DISPOSAL OF CONTAMINATED CARTRIDGE ELEMENTS MAY RESULT IN EXPOSURE TO CONTAMINANTS WHICH MAY CAUSE INJURY OR DEATH.

2. Remove the Battery and dispose of properly.

Batteries may have been contaminated by the atmosphere in which they were used and must be handled as a contaminated or potentially contaminated object.

- Dispose of rechargeable or damaged batteries in accordance with state and local environmental regulations.
- Do not throw away used cartridge elements or depleted or damaged batteries as ordinary waste.

Δ WARNING

DISPOSE OF DEPLETED OR DAMAGED BATTERIES IN ACCORDANCE WITH FEDERAL, STATE AND LOCAL ENVIRONMENTAL REGULATIONS. DO NOT THROW AWAY DEPLETED OR DAMAGED BATTERIES AS ORDINARY WASTE. IMPROPER HANDLING OF DEPLETED OR DAMAGED BATTERIES MAY RESULT IN INJURY OR DEATH.

CUSTOMER SERVICE INFORMATION

If you need additional information on the **Sentinel XT™ Full Hood PAPR** or any ILC Dover product, consult your distributor or contact:

Customer Service

ILC Dover
One Moonwalker Road
Frederica, DE 19946-2080
Phone: 800.631.9567 OR 302.335.3911, ext. 506
Fax: 302.335.1320
www.ilcdover.com

TROUBLESHOOTING

Use the table below to help identify possible causes and corrective action for problems you may experience.

Problem	Possible Cause	Corrective Action
Poor visibility through visor	Visor is coated with debris. Visor is scratched.	Wipe debris off. Dispose of hood and replace it with new hood.
Continuous low voltage alarm sounds upon blower activation	Battery is not charged.	Leave work area immediately. LiPolymer Battery: Switch to a fully charged battery, or recharge.
Low airflow	Battery needs charging. One or more cartridges are loaded. PAPR blower malfunction.	Leave work area immediately; switch to fully charged LiPolymer battery. Replace cartridges. Switch to a different blower unit.
Blower gasket is raised, twisted, or has any visible defects	Gasket is not properly seated into the blower and may produce a leak path	Contact ILC Dover Customer Service Department immediately 1-800-631-9567
Blower housing is cracked Battery pack is cracked	Mishandling of the equipment Improper use of the equipment or excessive use/and or damage	Leave work area immediately and replace with a new blower. Dispose damaged battery and replace.
Dents, Tears, Holes, or Cracks in the Hood or Breathing Tube	Mishandling of the equipment/Improper use of the equipment Not following the decon procedures properly. Excessive wear or damage	Leave work area immediately to prevent contaminated air from entering the hood or breathing tube. Dispose damaged hood or breathing tube and replace it with a new hood or breathing tube.

THIS PAGE INTENTIONALLY LEFT BLANK

THIS PAGE INTENTIONALLY LEFT BLANK